

EXS210044-01

EXS0650-006-10-0C00000

TO-8 Cooled Package 650nm

Revision: 1.0
Date: 03-05-2012
Confidentiality: **None**

Prepared by: Raffaele Rezzonico
(Product Support Technician)

Checked by: Chris Armistead
(Engineering Manager)

Approved by: Philippe Crépeillère
(Quality Manager)

Authorized by: Marcus Duell
(CTO)

CONTENTS

1.	SCOPE.....	3
1.1	PURPOSE	3
1.2	RESPONSIBILITY	3
2.	REFERENCE DOCUMENT	3
3.	ELECTRO-OPTICAL PERFORMANCE (T_{SLED} = 25°C)	3
4.	SCREENING TESTS	4
5.	ABSOLUTE MAXIMUM RATINGS	4
6.	PACKAGE DIMENSIONS [MM]	5
6.1	PACKAGE DIMENSIONS WITHOUT CAP	5
6.2	PACKAGE DIMENSIONS WITH CAP	5
6.3	PACKAGE PIN CONFIGURATION.....	6
6.4	PACKAGE ASSEMBLY TOLERANCES.....	7
6.5	SLED MOUNTING AXIS AND PACKAGE REFERENCE KEY ORIENTATION...	7
6.6	SLED EMISSION ANGLE	7
6.7	SLED WINDOW POSITION	7
6.8	SLED CENTRATION	8
6.9	TOLERANCES.....	8
7.	HEATSINKING / MOUNT REQUIREMENTS.....	8
8.	IMPORTANT NOTES.....	9
9.	ORDERING INFORMATION.....	9
9.1	TECHNICAL DESCRIPTION	9
10.	REVISION HISTORY	10

1. SCOPE

1.1 PURPOSE

The purpose of this document is to specify the electro-optical performance and dimensions of superluminescent light emitting diode (SLED) TO-8 cooled package.

1.2 RESPONSIBILITY

EXALOS is responsible for establishing, implementing and maintaining this procedure. The Quality representative shall ensure that a timely Engineering Change Notice (ECN) is issued in accordance with EXALOS procedure for any changes.

2. REFERENCE DOCUMENT

- EXS-WI-0001 Visual Inspection Criteria SLED Chip on Submount Procedure
- MIL STD 883 C method.
- Bellcore GR-468-CORE

3. ELECTRO-OPTICAL PERFORMANCE ($T_{SLED} = 25^{\circ}C$)

Parameter	Symbol	Min	Typ	Max	Unit
Operating Current	I_F	0		120	mA
Power ex-Window	P_o	5	10		mW
Centre Wavelength*	λ_0	630	650	670	nm
Bandwidth (3dB)	$\Delta\lambda_{3dB}$	4	6		nm
Vertical Far Field Angle	θ_{\perp}	-	40	-	deg
Horizontal Far Field Angle	θ_{\parallel}	-	15	-	deg

*Spectral verification is performed by sampling at the manufacturing batch level. Manufacturing batches are defined by epitaxial wafer growth run.

4. SCREENING TESTS

- Module environmental temperature cycling: -40°C to +85°C, ramp rate $\geq 5^\circ\text{C}/\text{min}$ 10 cycles according to MIL-STD-883, Method 1010
- Module seal:
 - Fine: condition A1,
 - Gross: Condition C according to MIL-STD-883, Method 1014

5. ABSOLUTE MAXIMUM RATINGS

Stresses beyond the absolute maximum ratings may cause permanent damage to the device. Exposure to absolute maximum rating conditions for extended periods may affect device reliability.

Parameter	Symbol	Cond.	Min	Max	Unit
Forward current	I_F			130	mA
Reverse voltage	V_R			-2	V
Forward voltage	V_F	$I_{F,\text{max}}$		3	V
Thermistor resistance	R_{th}	25°C	10		kΩ
Thermistor constant	B		3892		
TEC Heat Pump Temperature Difference ^{†§}	ΔT_{MAX}	$T_{\text{op}} > T_{\text{SLED}},$ $I_{F,\text{max}}$		30	°C
Thermoelectric cooler voltage	V_{tec}	25°C		2.5	V
Thermoelectric cooler current	I_{tec}	25°C		1.5	A
Storage temperature	T_{stg}		-40	85	°C
Operating temperature [‡]	T_{op}	$T_{\text{SLED}} = 25^\circ\text{C},$ $I_{F,\text{max}}$	-20	65	°C
Lead soldering temperature				260	°C
ESD		human b.m		300	V

[†] Heat pump capacity when module case (T_{op}) is above the temperature of the chip (T_{SLED}), i.e. TEC is cooling chip.

[‡] Measured at the case of the TO-CAN. Good heatsinking is essential to correct operation of the TO-CAN. See section 7, “HEATSINKING / MOUNT REQUIREMENTS”

6. PACKAGE DIMENSIONS [MM]

6.1 PACKAGE DIMENSIONS WITHOUT CAP

Tolerances: .X ± 0.25 mm unless stated
All Dimensions in mm

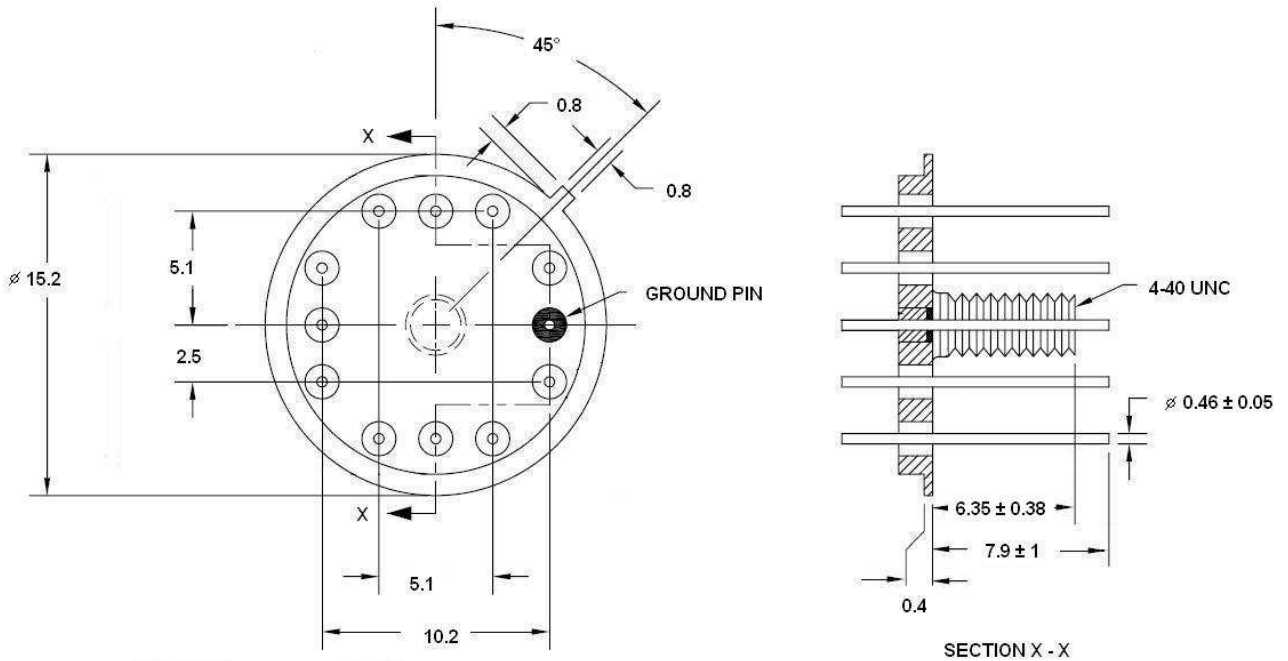

Package Top View (Window Side)

6.2 PACKAGE DIMENSIONS WITH CAP

Tolerances: .X ± 0.25 mm unless stated
All Dimensions in mm

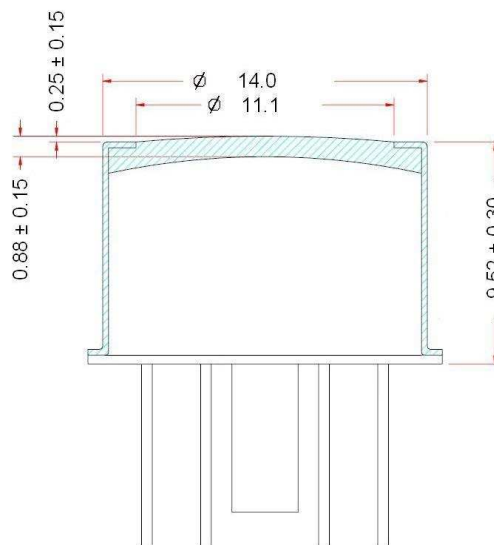

Package Side View

6.3 PACKAGE PIN CONFIGURATION

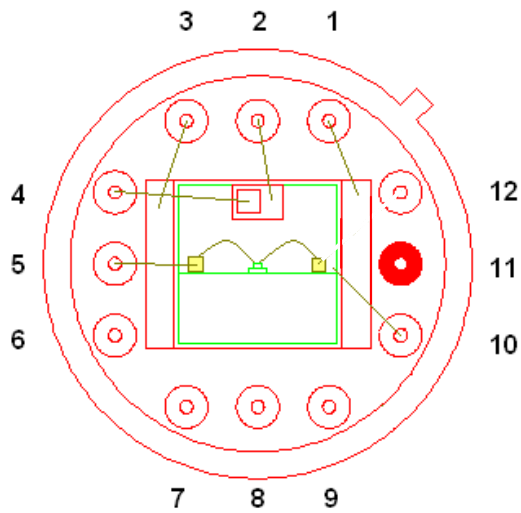

Package Top View (Window Side)

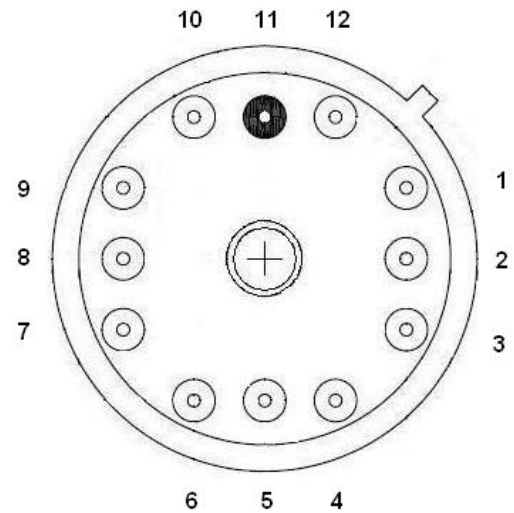

Package Back View (Pin Side)

Pin	Description
1	TEC Cathode
2	Thermistor
3	TEC Anode
4	Thermistor
5	SLED Anode
6	No Connection
7	No Connection
8	No Connection
9	No Connection
10	SLED Cathode
11	Case
12	No Connection

6.4 PACKAGE ASSEMBLY TOLERANCES

6.5 SLED MOUNTING AXIS AND PACKAGE REFERENCE KEY ORIENTATION

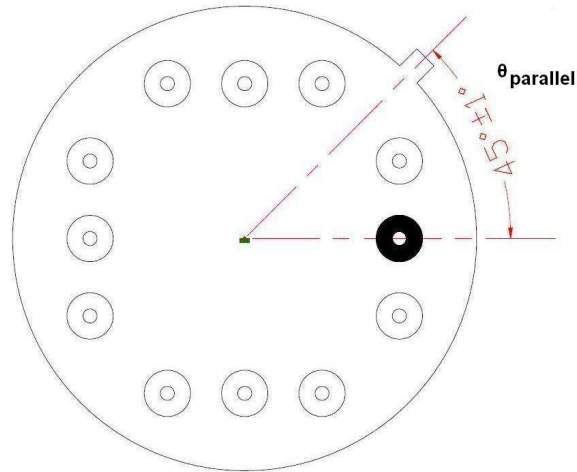

Package Top View (Window Side)

6.6 SLED EMISSION ANGLE

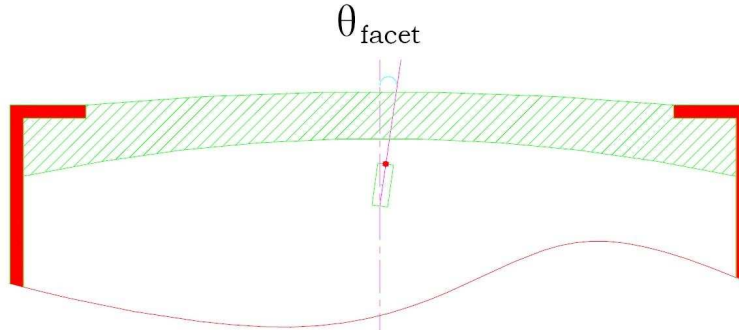

Cross section through TO-CAN cap window.

6.7 SLED WINDOW POSITION

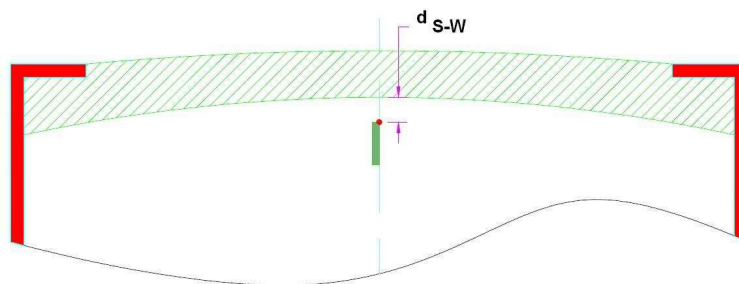

Cross section through TO-CAN cap window.

6.8 SLED CENTRATION

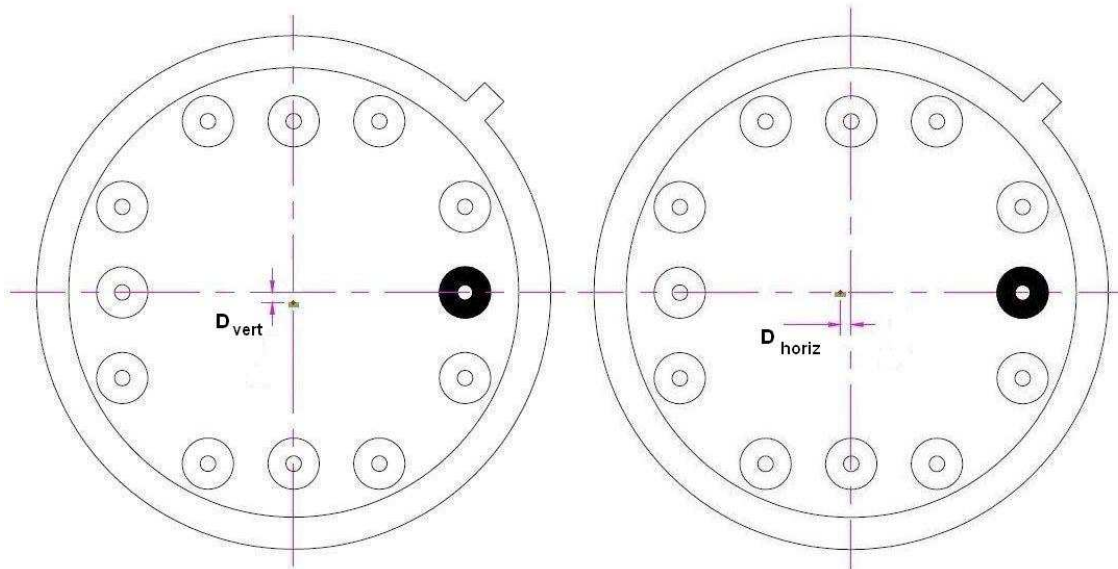

Package Top View (Window Side)

6.9 TOLERANCES

Design Item	Design Conditions	Detail
Emission orientation	Orientation between SLED mounting axis and package reference key	$\theta_{\text{parallel}} = 45^\circ \pm 1^\circ$
Emission angle	Angle between SLED chip facet and TO-CAN window	$\theta_{\text{facet}} = 0^\circ \pm 5^\circ$
SLED facet to TO-CAN window distance	Distance from SLED chip facet to TO-CAN inside window	$0.07 < d_{\text{S-W}} < 0.85 \text{ mm}$ Typical 0.47 mm
SLED Centration	Offset distance of SLED emission spot from TO-CAN axis	$D_{\text{horiz}} < 250\mu\text{m}$ $D_{\text{vert}} < 150\mu\text{m}$

7. HEATSINKING / MOUNT REQUIREMENTS

The specified performance of the module is only guaranteed when appropriate heatsinking is provided for the package. The TO8 package assembly requires heat pumped out of the SLED chip by the TEC and generated by the TEC itself to be extracted and dissipated so that the TEC heat pump does not experience a ΔT value greater than the specification (section 5).

The module thermal power generated at maximum TEC power and SLED power is approximately 3 Watts. The TO-CAN case must not rise above the maximum operating temperature defined in section 5. A heatpump assembly or heatsink capable of removing the thermal power from the TO-CAN base and stub is recommended. Good thermal contact between this heatsink and the TO-CAN base/stub is essential.

8. IMPORTANT NOTES

1. Avoid electrostatic discharges, which may destroy the SLED.
2. Never use the TO-CAN die without heat sinking.
3. Adequate eye protection against laser radiation should be used while handling and operating the module.
4. EXALOS declines any responsibility if the device is used in applications where human life may be endangered.
5. Back reflections may influence the output power and spectral characteristics of the SLED. The use of optical isolators and/or angled connectors is recommended. Back reflections of less than -30dB are recommended.

9. ORDERING INFORMATION

Please use the following **part number** to order product from EXALOS:

E X S 2 1 0 0 4 4 - 0 1

9.1 TECHNICAL DESCRIPTION

